

# Speed up your femtocell production Application

Test and measurement solutions for designing and manufacturing femtocell devices

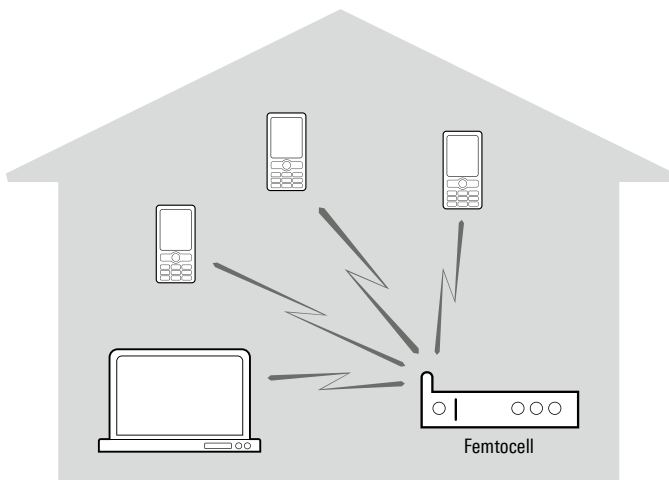

Femtocells are designed to provide improved mobile network coverage within buildings.

## Your task

Femtocells, or Home NodeB's (HNB), are small, low-cost cellular access points designed to provide improved mobile network coverage within buildings such as private homes and small-scale enterprises.

For mobile devices, femtocells operate like base stations, but at much lower power levels. Femtocells are connected to the operator's core network via a DSL or cable broadband connection. They are available on the market for a

wide range of cellular standards including WCDMA/HSPA, CDMA2000®, WiMAX™ and in the future also LTE.

Femtocells operate in an environment of macro base stations. To enable smooth integration into and operation within an existing network, femtocell manufacturers and chipset vendors alike need to manage interference scenarios, implement standard- and customer-specific requirements and ensure high product quality at the lowest possible costs.

## T&M solution

During a product development cycle, each stage has different test and measurement requirements.

In R&D, new technologies such as WiMAX™ and LTE require more advanced test and verification methods for higher-order modulation, MIMO and diversity testing. These very demanding test and measurement tasks can be addressed with the R&S®SMU200A vector signal generator with integrated realtime fading options prepared for up to 4x2 MIMO test cases. The R&S®FSQ signal analyzer demodulates and analyzes the MIMO streams for LTE and WiMAX™ applications.

When it comes to manufacturing, cost efficiency and fast yet accurate test solutions are the driving factors. Since a femtocell can be seen as a small base station with reduced output power, in general all tests typically used for macro base stations also apply to an HNB.

Due to the demand for efficient manufacturing tests, in practice only a subset of the parameters as proposed in the WCDMA base station conformance specification 3GPP TS 25.141 for example, are tested to ensure short test times.

One of the test parameters typically relevant in production is the transmitter modulation quality. This parameter is determined by error vector magnitude (EVM) measurements, adjacent channel leakage ratio (ACLR) and the maximum output power level to ensure that the femtocell transmitter fulfills the coverage requirements. Beside these standard RF parameters, the bit error rate / block error rate (BER/BLER) is tested to verify the sensitivity of a WCDMA receiver.

75 Years of Driving Innovation

  
**ROHDE & SCHWARZ**

Test & Measurement

Application Card | 01.00  
Speed up your femtocell production

A typical test setup is shown below, where the RF front-end is calibrated and verified by a signal generator and a signal and spectrum analyzer. An external PC controls the setup via GPIB or LAN interface. In order to ensure a fast calibration and verification process of the device under test (DUT), measurement times are a critical factor.

The R&S®SMBV100A vector signal generator and the R&S®FSV signal and spectrum analyzer were designed to meet the requirements for high volume production, providing fast switching and measurement times, an excellent price/performance ratio and on-site service capabilities. The R&S®FSV and the R&S®SMBV100A offer an internal electronic attenuator with fast switching times without wear and tear effects. The R&S®FSV is up to five times faster compared to other signal analyzers of the same class. Moreover, the analyzer features time-optimized measurement routines and high data throughput.

Rohde&Schwarz instruments are based on scalable multi-standard platforms, which support all major standards in one box, including WCDMA, HSPA, HSPA+, LTE, CDMA2000® and WiMAX™.

See also: [www.rohde-schwarz.com/technologies](http://www.rohde-schwarz.com/technologies)

CDMA2000® is a registered trademark of the Telecommunications Industry Association (TIA - USA).

“WiMAX” and “Mobile WiMAX” are registered trademarks of the WiMAX Forum.

## Key features and benefits of test and measurement solutions from Rohde & Schwarz:

- ▮ Low cost of ownership
- ▮ Low test cost due to high measuring speed
- ▮ Flexible and future-ready instruments due to multi-standard upgradeability

### R&S®SMBV100A vector signal generator:

- ▮ Realtime signal generation
- ▮ Multisegment waveform mode
- ▮ High-performance RF instrument
- ▮ High output power
- ▮ Supports the R&S®NRP-Zx power sensors

### R&S®FSV signal and spectrum analyzer:

- ▮ Fast switching and measurement times
- ▮ High throughput for efficient production
- ▮ Internal electrical attenuator
- ▮ Supports the R&S®NRP-Zx power sensors
- ▮ Outstanding RF properties

For further information, see also Application Notes:

**1MA144** How to run WCDMA BER/BLER tests using Rohde&Schwarz vector signal generators

**1MA143** LTE downlink MIMO verification with R&S®SMU200A and R&S®FSQ

**1MA142** Introduction to MIMO

## Manufacturing setup for calibration, verification and BER/BLER measurements on a femtocell DUT

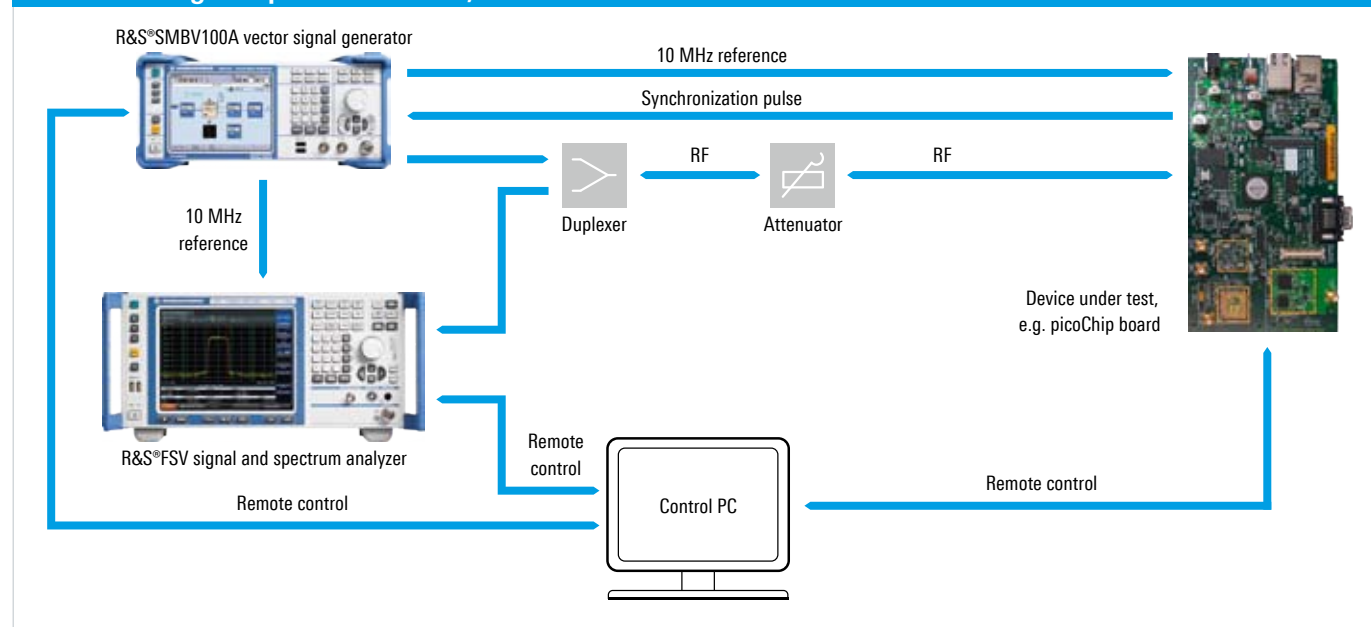

### Rohde & Schwarz GmbH & Co. KG

Europe, Africa, Middle East +49 1805 12 42 42\* or +49 89 4129 137 74

customersupport@rohde-schwarz.com

North America 1 888 TEST RSA (1 888 837 8772)

customer.support@rsa.rohde-schwarz.com

Latin America +1 410 910 7988

customersupport.la@rohde-schwarz.com

Asia/Pacific +65 65 13 04 88

customersupport.asia@rohde-schwarz.com

www.rohde-schwarz.com

R&S® is a registered trademark of Rohde & Schwarz GmbH & Co. KG

Trade names are trademarks of the owners

Femtocells | PD 5214.1795.92 | Version 01.00 | June 2009

Data without tolerance limits is not binding | Subject to change

Printed in Germany (sv)

\*0.14 €/min within German wireline network; rates may vary in other networks (wireline and mobile) and countries.